

# CCBanta

creative percussion company

ASSEMBLY INSTRUCTION MANUAL

Marimba Parts List

Item	Qty	Description
INSTRUMENT		
1.	1	Bottom Frame Assembly with casters
2.	1	Left side Support Frame
3.	1	Right side Support Frame
4.	1	Top Resonator Support Beam <u>C</u> (8 notes)
5.	1	Bottom Resonator Support Beam <u>D</u> (8 notes)
6.	1	Top Resonator Support Beam <u>E</u> (5 notes)
7.	1	Bottom Resonator Support Beam <u>F</u> (5 notes)
8.	1	13 note Upper frame assembly with Bars
9.	1	Music Stand
10.	2	Music Stand Supports
RESONATORS		
11.	1	CC Mitered "L" Resonator
12.	1	CC# Mitered "U" Resonator
13.	1	DD Mitered "L" Resonator
14.	1	DD# Mitered "U" Resonator
15.	1	EE Mitered "L" Resonator
16.	1	FF Mitered "L" Resonator
17.	1	FF# Mitered "L" Resonator
18.	1	GG Semi-mitered Resonator
19.	1	GG# Semi-mitered Resonator
20.	1	AA Straight Resonator
21.	1	AA# Straight Resonator
22.	1	BB Straight Resonator
23.	1	C Straight Resonator
HARDWARE		
24.	8	3" X 5/16" Lag Bolts
25.	16	3 1/2" X 5/16" Carriage Bolts
26.	8	4 1/2" X 5/16" Carriage Bolts
27.	32	5/16" Flat Washers
28.	24	5/16" Nuts
29.	8	5/8" X 8 Pan Head Screws
MISCELLANEOUS		
30.	1pr.	No. 17 Mike Balter Bass Marimba Mallets
31.	1pr.	No. 18 Mike Balter Bass Marimba Mallets
32.	1	Mallet Rack
33.	1	2 oz. bottle Aliphatic Resin
34.	1	Assembly Instruction Manual
Carton Contents		
Box 1 of 8		Bottom frame with casters, side support rails, resonator cross beams, and music stand with supports.
Box 2 of 8	}	Resonators
Box 3 of 8		
Box 4 of 8		
Box 5 of 8		
Box 6 of 8		
Box 7 of 8		
Box 8 of 8		Misc. supplies; mounting hardware, glue, 2 pairs of Mallets, mallet rack, and Assembly Instruction Manual.

STEP 1

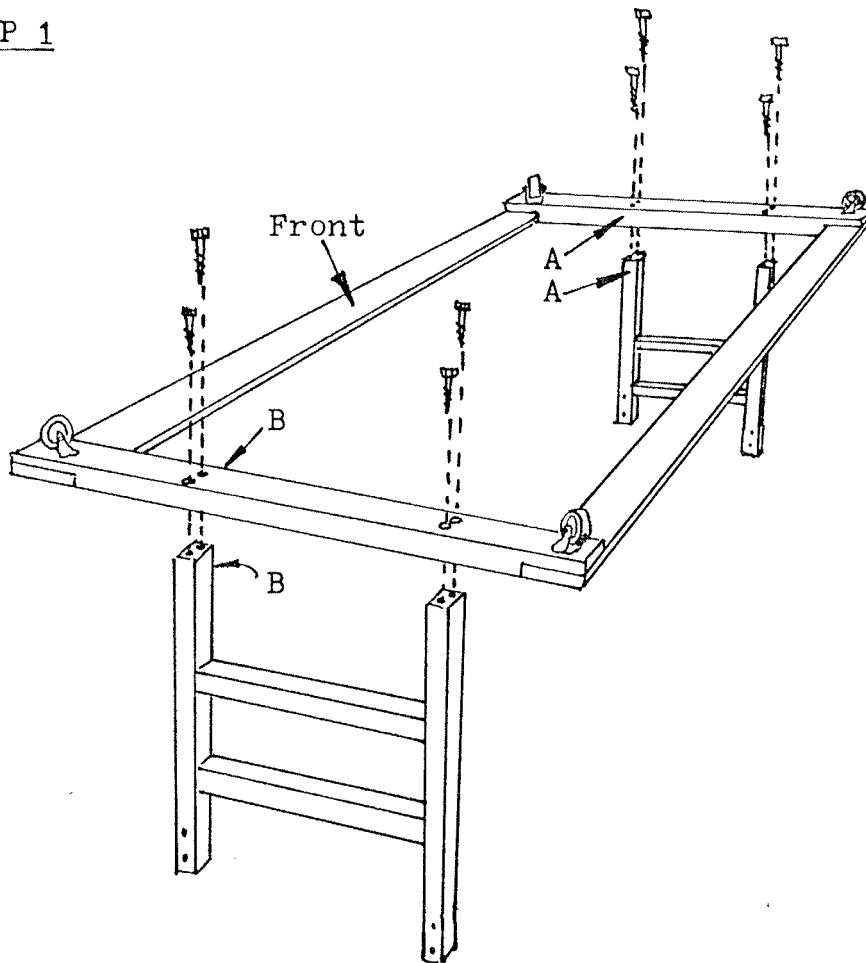

Add "Side Supports"  
A and B to bottom  
of frame assembly.

Use (8) 3" X 5/16"  
Lag bolts, washers,  
and nuts.

STEP 2

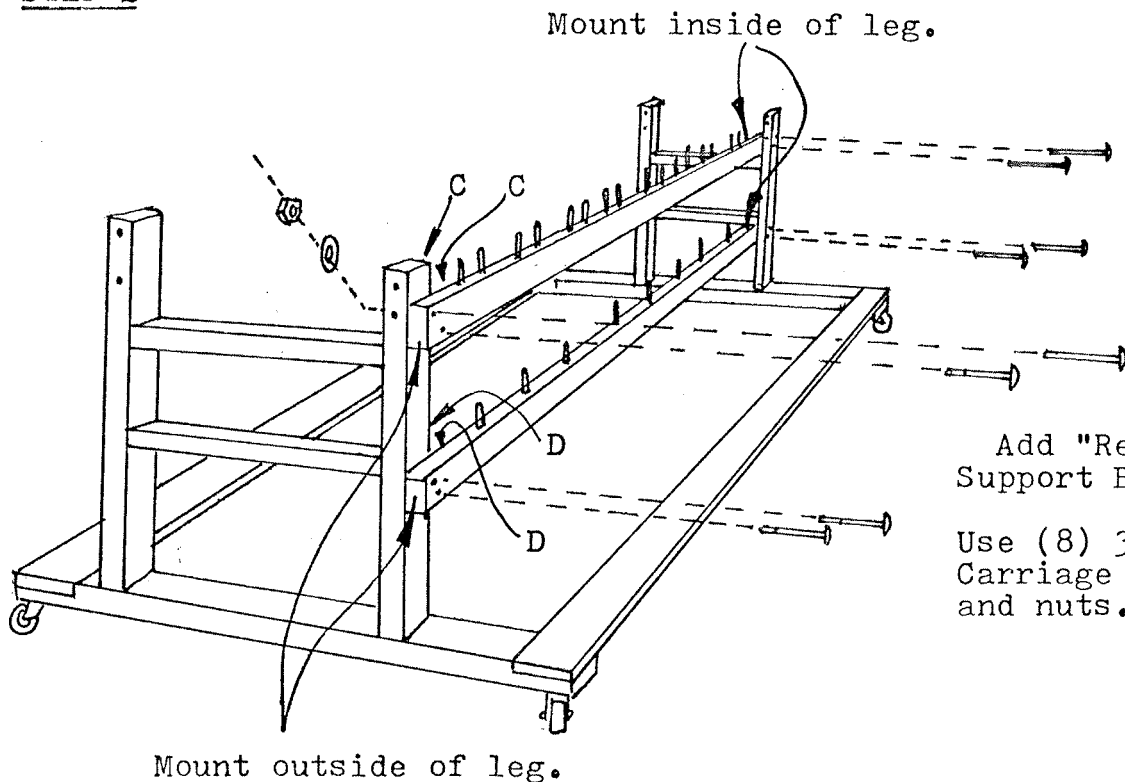

Mount inside of leg.

Add "Resonator  
Support Beams" C and D.

Use (8) 3½" X 5/16"  
Carriage bolts, washers,  
and nuts.

Mount outside of leg.

STEP 3

Add "Resonator Support Beams"  
E and F.

Use (8)  $4\frac{1}{2}$ " X  $\frac{5}{16}$ " Carriage  
bolts, washers, and nuts

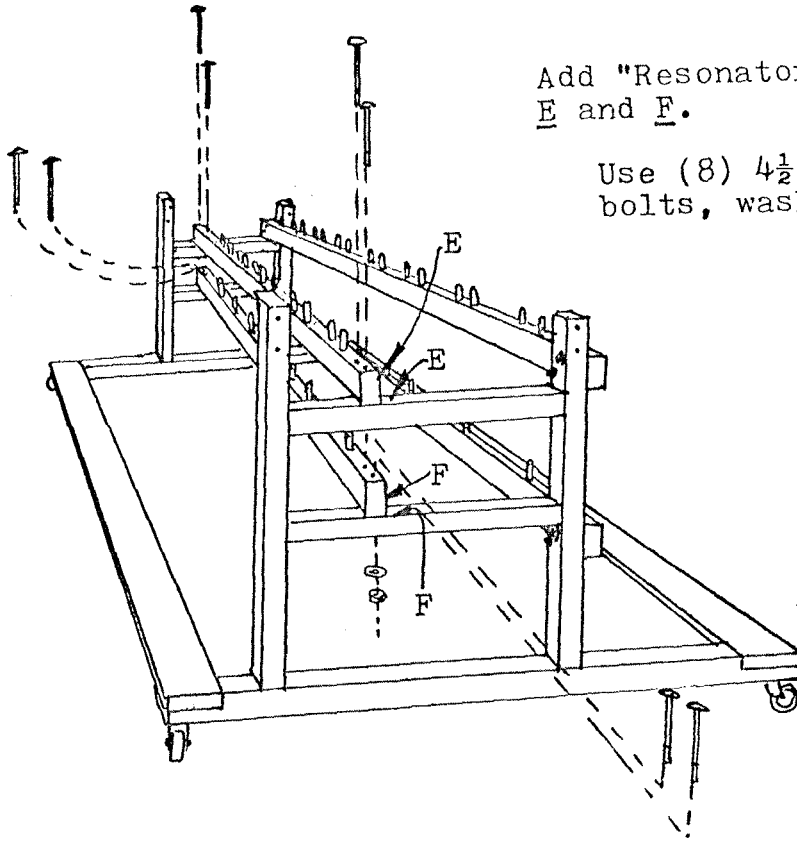

STEP 4

Mount all Resonators as shown below.  
Start with back row first.

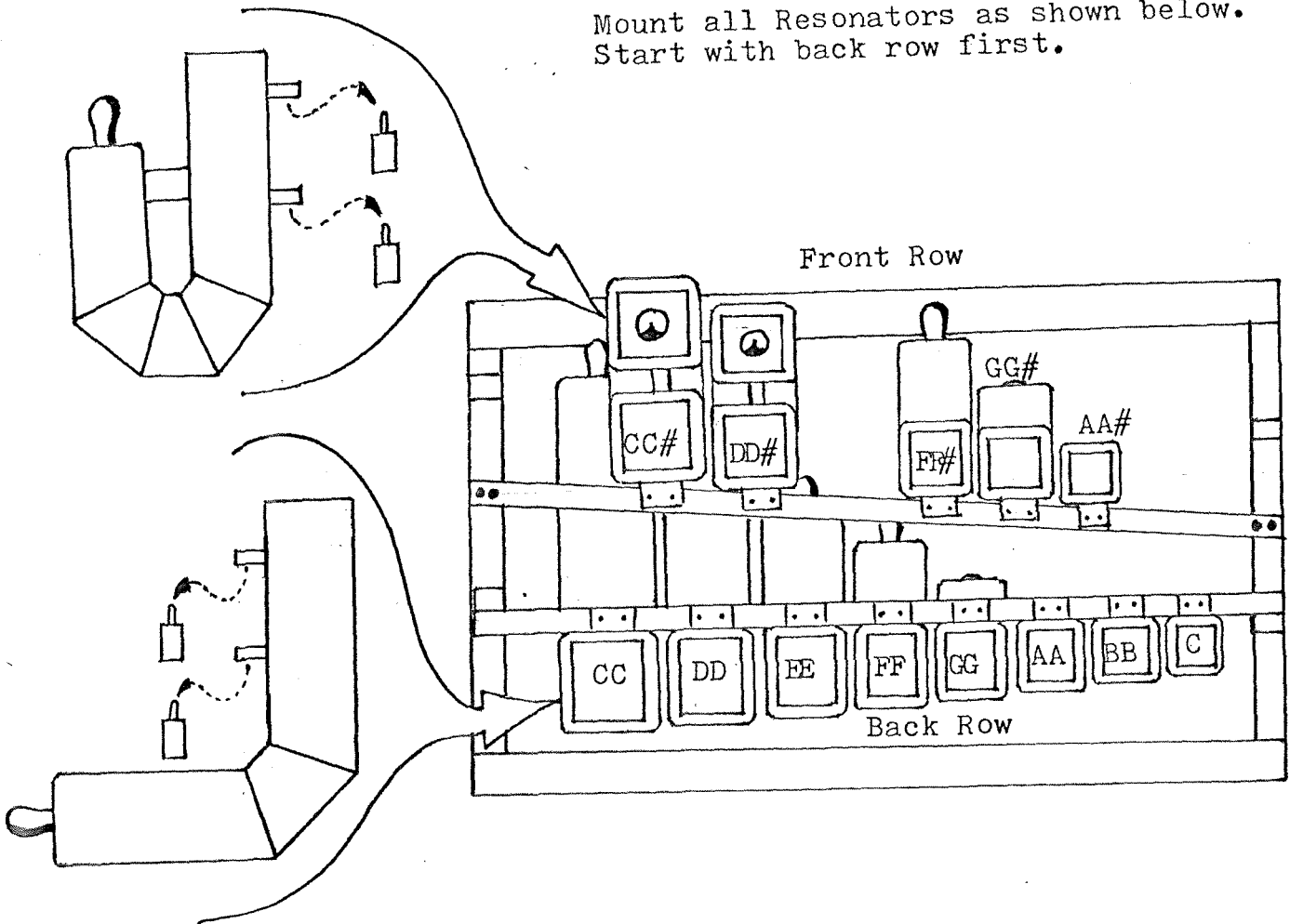

STEP 5

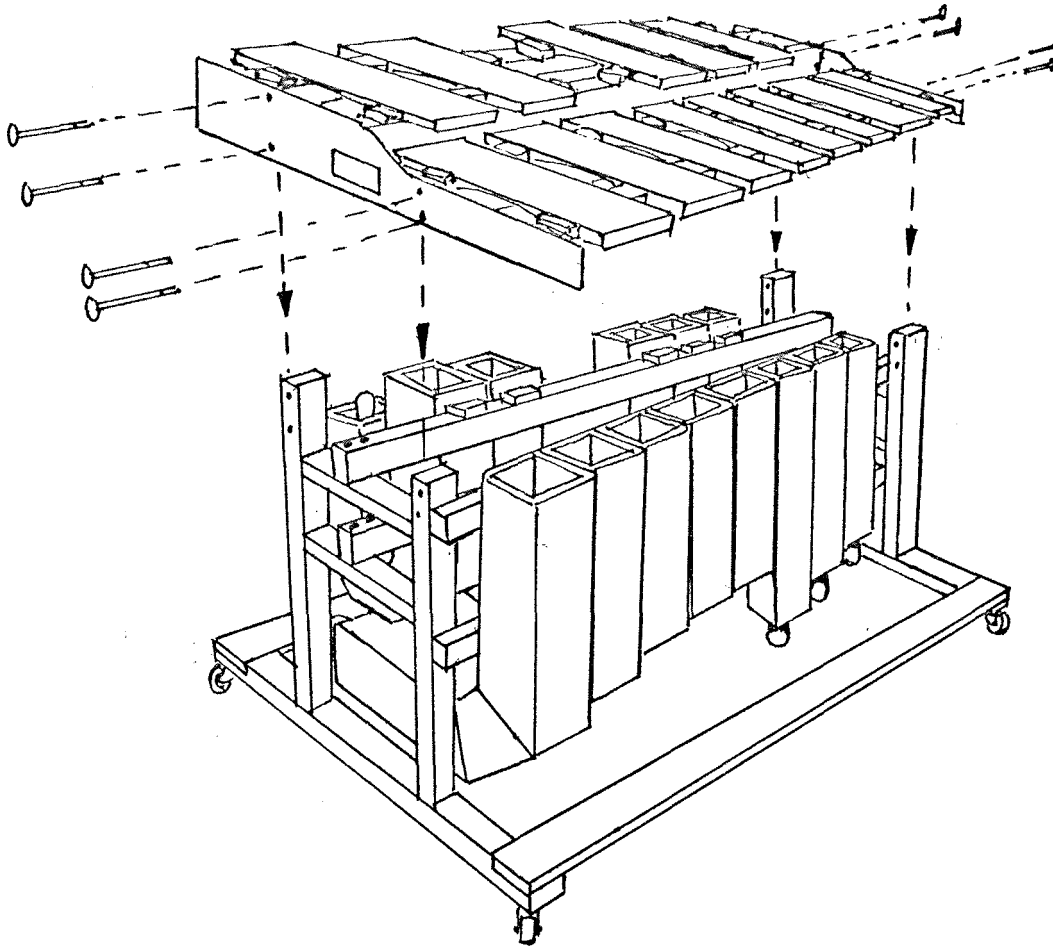

Slowly lower Marimba Bars onto main frame assembly. Use two people for this operation.

Use (8)  $3\frac{1}{2}$ " X  $\frac{5}{16}$ " Carriage bolts, washers, and nuts.

STEP 6

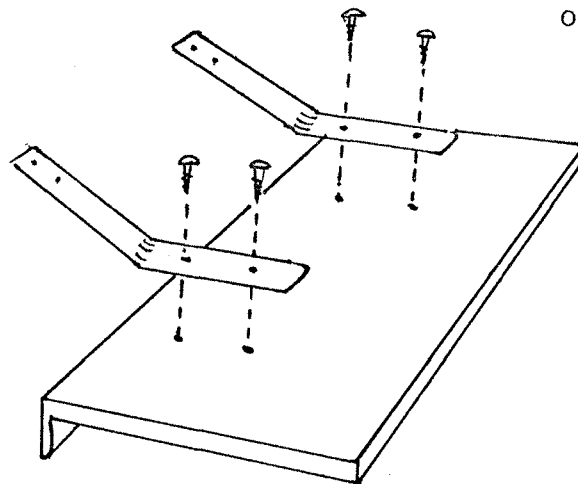

Mount music stand supports onto Music Stand.

Use (4)  $\frac{5}{8}$ " X 8 pan head screws.

STEP 7

Mount Music Stand assembly onto  
Bass Marimba.

Use (4) 5/8" X 8 pan head screws.

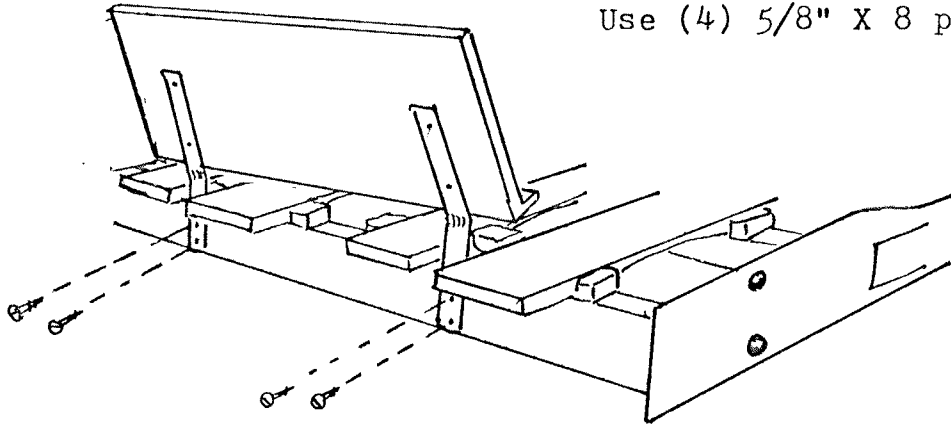

Bars

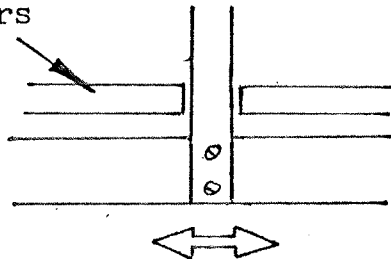

Note:  
Make sure Music Stand  
Supports don't touch  
the sides of the bars.